

PREPARE FOR **IMPACT**

EXCEL
STORAGE PRODUCTS



STEEL-CLAD[®]

PROTECT YOUR STORAGE RACK SYSTEM FROM COSTLY FORKLIFT DAMAGE WITH EXCEL STEEL-CLAD[®] IMPACT PANELS. STEEL-CLAD GIVES YOU SIGNIFICANTLY MORE IMPACT RESISTANCE THAN CLOSED BOX COLUMNS, COLUMN PROTECTORS OR DOUBLE COLUMNS. SEE THE REVERSE SIDE FOR ALL THE ADVANTAGES OF STEEL-CLAD FROM EXCEL.

Steel-Clad panels in the photo have been coated for emphasis. Actual Steel-Clad inserts are not powder coated.



IMPACT PANELS

With more than 200% of the steel in a standard structural frame, STEEL-CLAD welded inserts effectively reinforce along the sides of the column and all the way to the front corners, where most damage is likely to occur.

Prevent costly forklift damage with EXCEL STEEL-CLAD® impact panels.

Manufactured exclusively by EXCEL, STEEL-CLAD impact panels are high-strength internal column reinforcements that use no more space than a normal column.

STEEL-CLAD impact panels are made by welding extra heavy-duty 3/16" thick steel inserts to the inside of a regular column to form a solid closed box column.

STEEL-CLAD panels are an economical and space-saving alternative to double column reinforcements and external column protectors. Your storage rack system can be designed to include Steel-Clad panels only where needed and only as high as needed.

STEEL-CLAD panels provide triple the impact resistance of a standard structural frame, while preserving the advantages of a roll-formed frame, including self-engaging boltless beam connections.

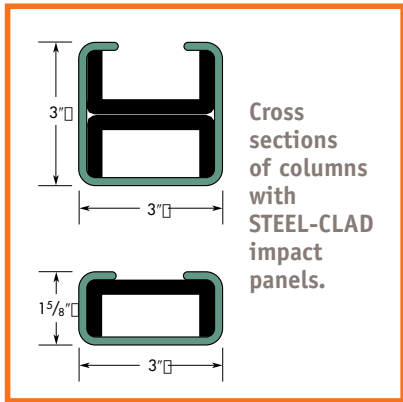
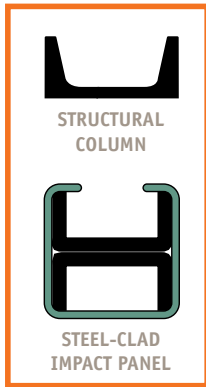
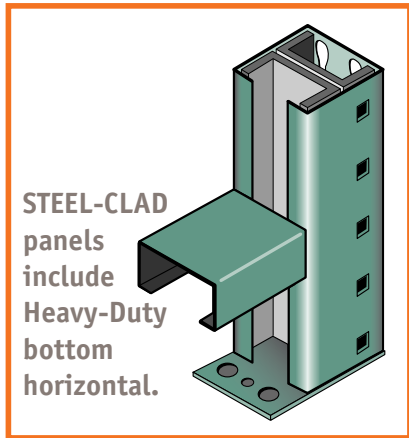
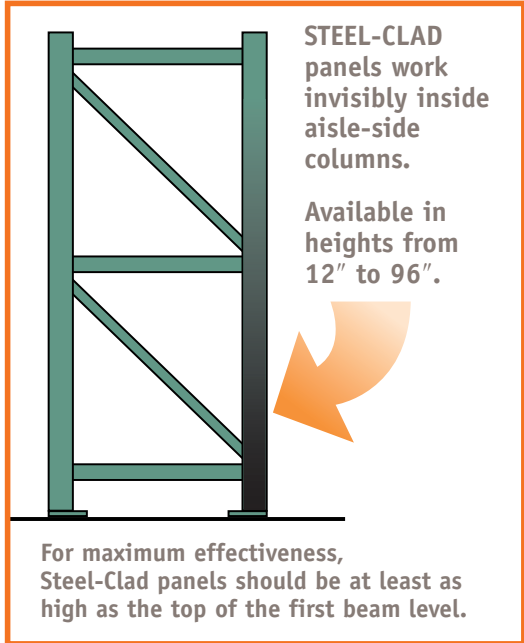

All Steel-Clad panels are factory-installed. Reinforcement of front column is not intended to increase column capacity but rather to increase resistance to lift truck abuse.

EXCEL STORAGE PRODUCTS



PALLET SELECTIVE / DRIVE-IN / PUSH-BACK / DOUBLE DEEP / BULK STORAGE / ARCHIVE STORAGE / RETAIL DISPLAY
RACK SUPPORTED BUILDINGS & MEZZANINES / CUSTOM DESIGNED STORAGE SYSTEMS / CUSTOM DESIGNED COMPONENTS

P. O. BOX 407, EAST STROUDSBURG, PA 18301-0407 • (570) 476-1010 • FAX: (570) 476-4358 • e-mail: esp@esprack.com

www.esprack.com